

VOIP Analysis Solution for Carrier Markets

Introduction

Many traditional cable television companies are using their existing infrastructure to provide telephone service to residential and business markets. While this service is economical and convenient for consumers, additional resources to maintain this service are required. Application analysis for Voice over IP (VOIP) is time sensitive and dramatically impacts customer satisfaction. Carriers are developing new ways to monitor and analyze VOIP traffic.

Framework

A Cable Modem Termination System (CMTS) is a computerized device that enables cable modems to send and receive packets over the Internet. It inserts IP packets from the Internet into MPEG frames and transmits them to the cable modems via an RF signal. It does the reverse process coming from the cable modems.

A CMTS may provide filtering to protect against theft of service and denial of service attacks or against hackers trying to break into the cable operator's system. It may provide traffic shaping in order to guarantee a specified quality of service (QoS) to selected customers.

The VOIP Analyzer is a carrier-grade, scalable, multiservice probe. Through traffic monitoring, the VOIP Analyzer detects patterns of QoS degradation to identify the source of a problem.

Analysis

Typical hub deployments range from two or more CMTS systems connected to a router. VOIP analysis at the hub level is required to maintain QoS and troubleshoot problems.

Taps provide a secure point of analysis between the CMTS and the router. Tap design specifications ensure network connectivity. Analysis with information from a tap does not require the use of a router port or any router configuration.

The figure below (Fig. 1) depicts multiple CMTS systems that connect via a router. Inter-CMTS VOIP is relatively low volume and low utilization traffic. A single VOIP Analyzer is adequate to handle a hub for VOIP interrogation.

In this example, completely passive fiber optic taps are used for hub locations with four or less CMTS systems. These are non-powered fiber optic taps that send a copy of the network traffic to a VERSAstream™ aggregation device. The fiber optic taps do not generate any delay and little signal loss on the connection. The aggregator combines all of the data together to send to a single interface on the VOIP Analyzer. As long as the combined traffic is below the 1000Mb receive capability of the VOIP Analyzer no data will be lost.

Figure 1- Datacom Systems VOIP Analysis Solution for low density CMTS site

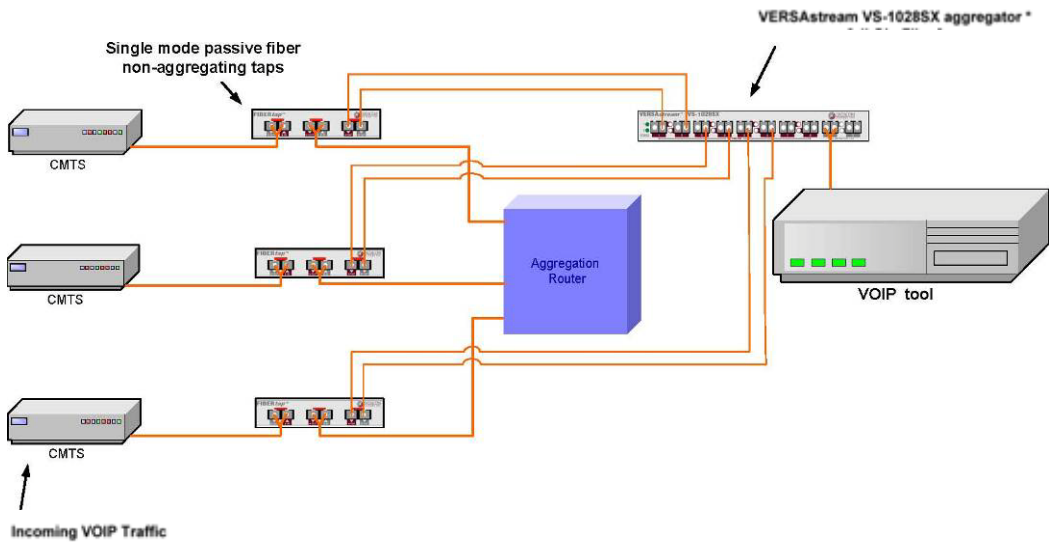

Locations that have more than four CMTS devices use an aggregation tap to gather data between the CMTS and the router. The aggregation tap combines the network link data between the CMTS and the router into a single output. These outputs are combined for presentation to the VOIP Analyzer by the VERSAstream™. A lower port density VERSAstream™ may be substituted for hub locations that have two CMTS. If additional CMTS devices are added, another VERSAstream™ model can be added to handle the additional ports.

Figure 2- Datacom Systems VOIP Analysis Solution for high density CMTS site Design Considerations

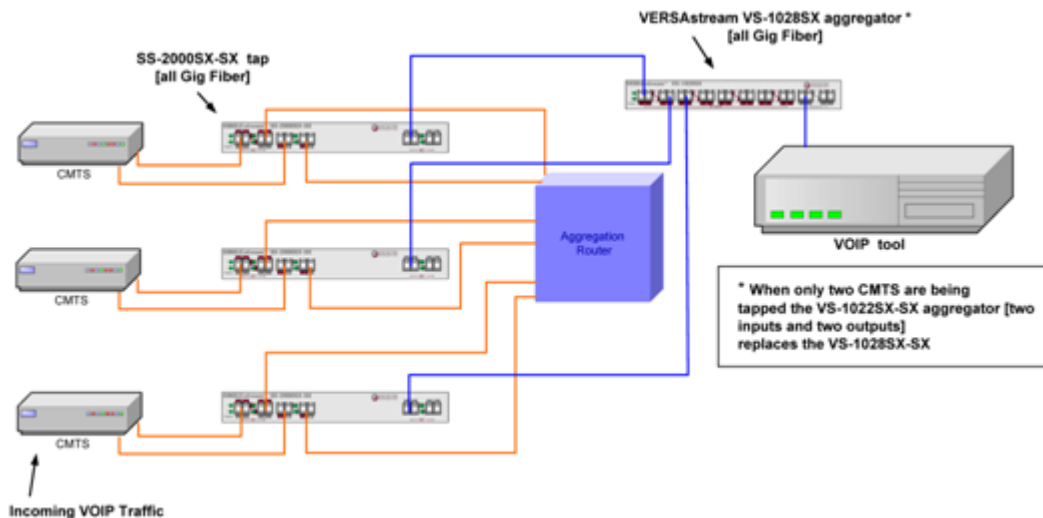

Design considerations for this type of analysis are determined by the analysis technique and network layout. In these examples, the following criteria applied:

- Taps were required to eliminate the use of a network device port, see more information than available via long term SPAN ports, and not introduce a point of failure into the network.

- Network utilization was low enough to allow a single analysis device to see traffic from a number of CMTS locations.
- Modular components are used to allow a “cookie cutter” approach to hub locations, but allow hubs to become upgraded in the future if port density becomes an issue.